

TRUCK-MOUNTED CONCRETE PUMP SYG5350THB 490C-10

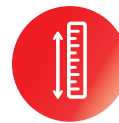

Highly Reliable

- SANY has World-class lighthouse factories with top-level manufacturing capability, assuring reliable quality.
- Careful matching of components ensures stable performance of the whole machine.



Strong Pumping

- Hydraulic system automatic mode: Stepless pressure system
- Multiple upgrades assure high suction rate
- Significant advantage in pumping efficiency



Extremely Economical

- The industry-leading longest service life of wear parts
- Advanced fuel combustion technology
- Targeted upgrades for different working conditions



Ultimate User Experience

- Comfortable cab comparable to passenger car experience
- Multi-language human-machine interface
- Easy-maintenance



TECHNICAL SPECIFICATION

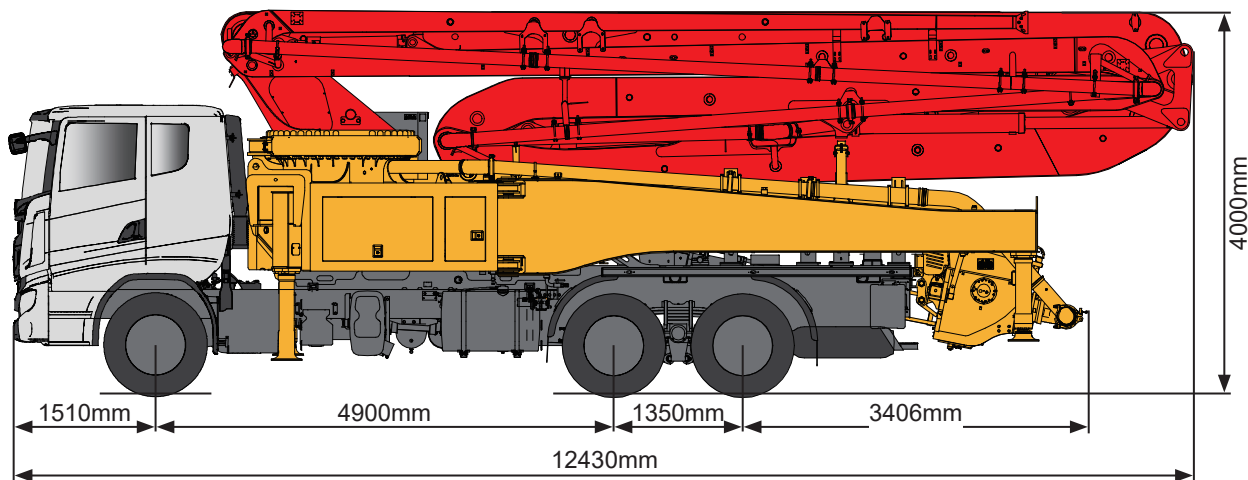

Note: standard dimensions version for SANY SYG5350THB 490C-10

TECHNICAL DATA

Boom

Vertical reach	48.6 m
Horizontal reach	43.6 m
Depth reach	30.8 m
Unfolded reach	13.9 m
Rotation	± 360 °
Front outrigger spread L-R	9200 mm
Rear outrigger spread L-R	9700 mm
End hose length	3 m
End hose diameter	125 mm
Pipeline size	125 mm

Pumping system

Theoretical output	180 m ³ /h
Theoretical pressure	12 MPa
Delivery cylinder diameter	260 mm
Stroke length	1900 mm
Hydraulic system	Open
Hydraulic system oil pressure	32 MPa
Oil tank capacity	680 L
Water tank capacity	620 L

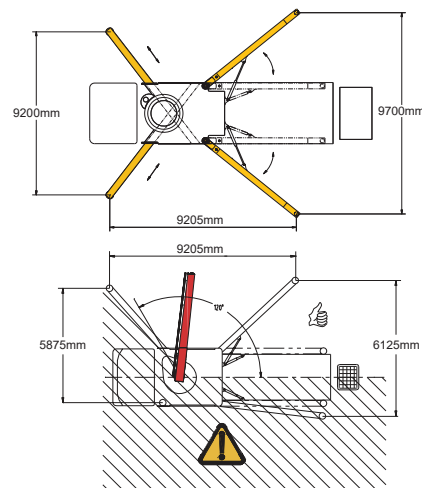

DELIVERY & CONFIGURATIONS

Chassis

Brand: SANY
Model: SYM5350THB1E / SYM5350THB1C
Engine type: D12C5-490E0 / D12C3-490E0
Engine max net power: 348/1900 kW/rpm
Emission standard: Euro V / Euro III
Capacity of fuel tank: 600 L
Displacement: 12.12 L
Max.speed: 90 km/h

Functions

Agitator rotation, 2 direction
Single-button double piston return
Stepless Pressure System
Auto-lubrication fore core pump

Safety

Mushroom button for horn, yellow
Emergency stop
Hopper plate

Cleaning

Sponge balls
High-pressure water pump

Others

Remote control System, wired (optional)
Industrial display control screen 10"(optional)
Operating manual
MachineLink+ APP/web connected
7 × 24 service with no worry

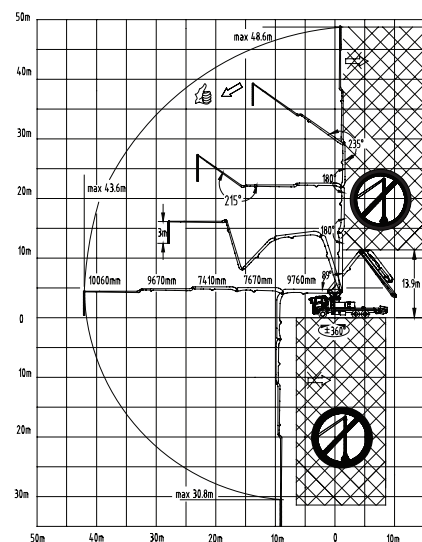

www.sanyglobal.com

SANY Industrial Park, Economic and Technological Development Zone,
Changsha, Hunan, China, 410100
Sales Hotline
Tel: 0086-731-85835199
Mail: sales@sanyglobal.com

Service Hotline
Tel: 0086-4006098318
Mail: CRD@sany.com.cn

The product configuration (including technical parameters) is subject to change and the delivered actual machine without notice.